

SEM

POR GUMPERTZ

Servicios, Equipos y Maquinarias S. P. A.
Una empresa de Ronald Gumpertz

 **Números telefónicos:**

(+56) 9 9682-3138

(+56) 9 4948-2503

 **Dirección de correo electrónico:**

contacto@gumpertz.cl

 **Dirección física:**

Domeyko 2500 (Santiago Centro)

Nuestra empresa

Somos una fábrica e importadora dedicada a la manufacturación y venta de pernos, herramientas industriales, equipos eléctricos, ferretería industrial y maestranza.

Nuestras redes sociales



Sitio web: www.semgumpertz.cl

HYDRAFAST TOOLING

HYDRAPAC[®] HYDRAULIC POWER UNITS

HydraPac[®] hydraulic power units are compact, portable and available in 220v, 380v and 525v models. The pump solenoid and combination valves are all housed and submerged within the oil reservoir. The electrics are in a separate dry compartment and mounted externally on the motor.

A unique feature is that the motors only run on demand, when you close the tool trigger, it remains running whilst a series of fasteners are driven. At the end of the series if there is no further demand for a preselected (variable) time, the unit switches off, a touch of the tool trigger starts the unit instantly. Conserving power and enhancing system life.

If for any reason the hydraulic system is loaded to maximum pressure, the main relief valve will open and remain open, dropping the system pressure to a few bars until the unit is switched off or goes into sleep mode. This safety feature also ensures that the unit is never subjected to excessive overload. These units are also available in dual that allow operation of two hydraulic tools.



| HYDRAPAC MODEL NO. | HP21 | HP41 | HP51 |
|--------------------|-------------------------------------|-------------|--------------|
| MOTOR | 2,2kw, 4 Pole coupling driven mount | | |
| VOLTS | 220, 1Ph | 380, 3Ph | 525, 3Ph |
| AMPS / Hz | 15A / 50hz | 5.3A / 50hz | 3.8A / 50 hz |
| LENGTH mm | 815 | | |
| WIDTH mm | 360 | | |
| HEIGHT mm | 530 | | |
| WEIGHT kg | 98 (with full tanks) | | |



| HYDRAPAC MODEL NO. | HPD1 |
|--------------------|---|
| MOTOR | HOFFMAN HP78 Diesel engine |
| PUMP | Hawe Elements |
| CONTROL | 12v DC Trigger Operated |
| WORKING PRESSURES | Pull - 55.2mPa (8000Psi) Return - 21mPa (3000 Psi) |
| PUMP CAPACITY | 5.4 min at 3000 RPM |
| LENGTH mm | 900 |
| WIDTH mm | 400 |
| HEIGHT mm | 700 |
| WEIGHT kg | 145 (with full tanks) |

A RANGE OF CE COMPLIANT
LOCALLY DESIGNED,
DEVELOPED & MANUFACTURED
LOCKBOLT INSTALLATION TOOLING



| HOSE & CORD KIT | HS13 | HS16 | HS14 |
|-----------------|------|------|------|
| LENGTH mm | 6 | 10 | 15 |
| WEIGHT kg | 5.0 | 7.0 | 12.5 |

other lengths available on request

Data shown is subject to change without prior notice as a result of continuous product development and improvement . Rev 2014

HYDRADRIV® 10-28mm

BASIC DIMENSIONS

| HYDRADRIV MODEL NO. | T10 | T30 | T51 |
|---------------------|--------|---------|---------|
| LOCKBOLT RANGE | 5 - 10 | 13 - 19 | 22 - 28 |
| A | 118 | 143 | 205 |
| B | 60 | 89 | 122 |
| C | 176 | 203 | 217 |
| WEIGHT kg | 3.5 | 8.0 | 18.0 |

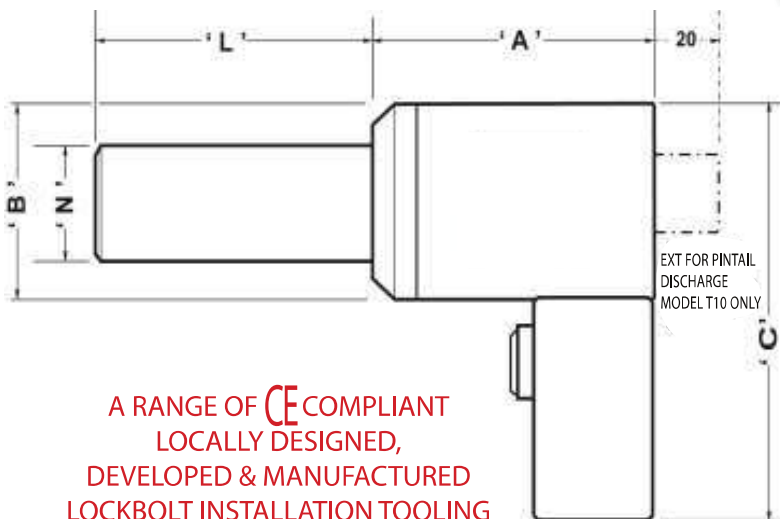

A RANGE OF CE COMPLIANT
LOCALLY DESIGNED,
DEVELOPED & MANUFACTURED
LOCKBOLT INSTALLATION TOOLING



NOSE SELECTION

| T10 | | | | T30 | | | | T51 | | | |
|---------|---------------|----|------|---------|---------------|-----|----|---------|---------------|-----|----|
| NOSE NO | LOCKBOLT TYPE | L | N | NOSE NO | LOCKBOLT TYPE | L | N | NOSE NO | LOCKBOLT TYPE | L | N |
| N10 | 10 STD | 89 | 28 | N30 | 19 STD | 131 | 56 | N50 | 25 STD | 153 | 83 |
| N11 | 3/8" BLIND | 86 | 28.5 | N31 | 16 STD | 113 | 48 | N52 | 28 STD | 158 | 83 |
| G06 | 6 MG | 69 | 20 | N32 | 13 STD | 110 | 43 | N53 | 22 STD | 148 | 70 |
| G10 | 10 MG | 90 | 33 | N35 | 19 BLIND | 130 | 56 | | | | |

HYDRAFAST TOOLING

HYDRADRIV[®] CLOSE QUARTER

13-28mm

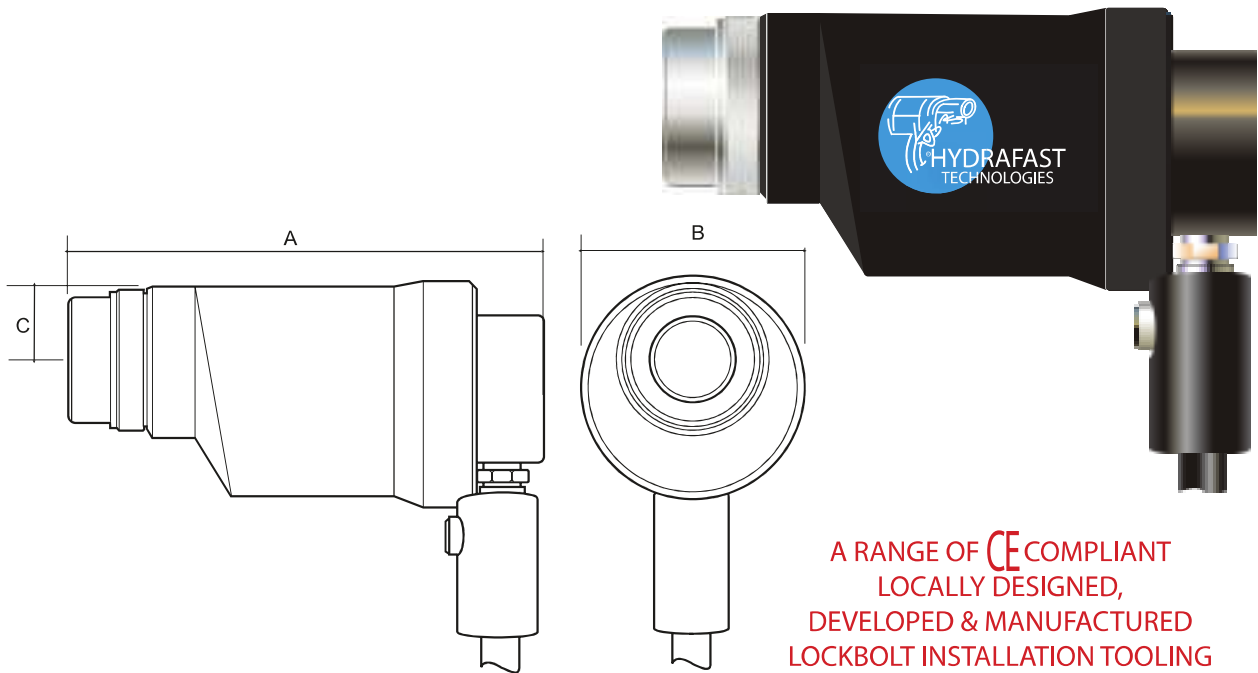

TOOL SELECTION

| HYDRADRIV MODEL NO | T32 | T33 | T34 | T35 | T36 |
|--------------------|-------------------------|---------------------|---------------------|---------------------|---------------------|
| LENGTH (A) | 182 mm 7.16 in | 194 mm 7.64 in | 217 mm 8.54 in | 217 mm 8.54 in | 217 mm 8.54 in |
| BODY DIAMETER (B) | 86 mm 3.38 in | 96 mm 3.78 in | 130 mm 5.12 in | 130 mm 5.12 in | 130 mm 5.12 in |
| BACK MARK (C) | 31 mm 1.22 in | 34.5 mm 1.36 in | 48.5 mm 1.9 in | 48.5 mm 1.9 in | 48.5 mm 1.9 in |
| WEIGHT | 6.3 kg 13.9 lbs | 7.7 kg 17 lbs | 15 kg 33 lbs | 15 kg 33 lbs | 15 kg 33 lbs |
| STROKE | 33 mm 1.3 in | 33 mm 1.3 in | 41 mm 1.6 in | 41 mm 1.6 in | 41 mm 1.6 in |
| PULL PRESSURE | 55.2 mPa 8000PSI | 55.2 mPa 8000PSI | 55.2 mPa 8000PSI | 55.2 mPa 8000PSI | 55.2 mPa 8000PSI |
| RETURN PRESSURE | 20.7 mPa 3000PSI | 20.7 mPa 3000PSI | 20.7 mPa 3000PSI | 20.7 mPa 3000PSI | 20.7 mPa 3000PSI |
| HYDRAULIC FLUID | ISO VG 46 or Equivalent | | | | |
| FASTENER RANGE | 16 mm | 19 mm | 22 mm | 25 mm | 28 mm |
| NOISE LEVEL | 126 dB (A) | | | | |
| SOUND POWER | 100.9 dB (A) | | | | |
| VIBRATION | 8.6 m/sec ³ | | | | |

Data shown is subject to change without prior notice as a result of continuous product development and improvement . Rev 2014

HYDRADRIV[®] SLIMLINE

13-19mm

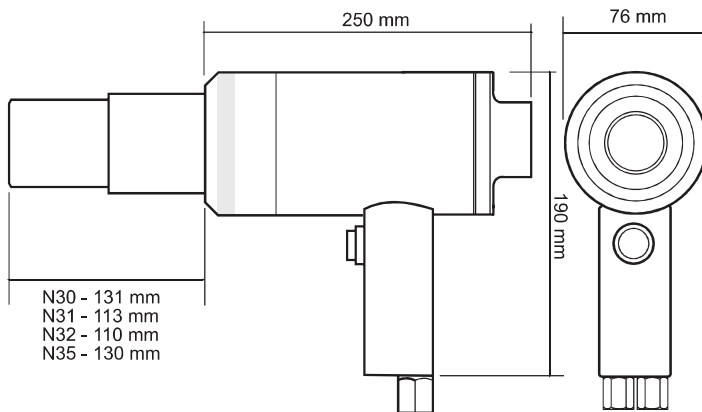

A RANGE OF **CE** COMPLIANT
LOCALLY DESIGNED,
DEVELOPED & MANUFACTURED
LOCKBOLT INSTALLATION TOOLING

BASIC DIMENSIONS

| HYDRADRIV MODEL NO | T40 | | | |
|--------------------|-------------------------|-----------|-----------|-----------|
| LENGTH (A) | 250 mm | | 9.8 in | |
| BODY DIAMETER (B) | 76 mm | | 2.9 in | |
| HEIGHT | 190 mm | | 7.5 in | |
| WEIGHT | 7 kg | | 15.4 lbs | |
| STROKE | 41 mm | | 1.6 in | |
| PULL PRESSURE | 55.2 mPa | | 8000 PSI | |
| RETURN PRESSURE | 20.7 mPa | | 3000 PSI | |
| HYDRAULIC FLUID | ISO VG 46 or Equivalent | | | |
| FASTENER RANGE | 19 mm STD | 13 mm BOM | 16 mm BOM | 19 mm BOM |
| NOISE LEVEL | 126 dB (A) | | | |
| SOUND POWER | 100.9 dB (A) | | | |
| VIBRATION | 8.6 m/sec ³ | | | |

HYDRADRIV[®] COLLAR SPLITTER

13-28mm



TECHNICAL DATA

| HYDRADRIV MODEL NO | S30 | S50 |
|--------------------|----------------------------|----------------------------|
| CAPACITY | Lockbolts 13 - 19 mm | Lockbolts 22 - 28 mm |
| | Grade 8 Nuts 12 - 20 mm | Grade 8 Nuts 22 - 27 mm |
| STROKE | 20 mm | 20 mm |
| WORKING PRESSURE | 57 Mpa | |
| | 8000 PSI | |
| LENGTH | 210 | 248 |
| HEIGHT | 90 | 110 |
| WIDTH | 60 | 65 |
| WEIGHT | 4.6 kg | 7.8 kg |
| MOVING BLADE | | |
| S30 | LS3010 | |
| S50 | | LS5010 |
| FIXED BLADES | | |
| 13 MM | LS3013 | |
| 16 MM | LS3016 | |
| 19 MM | LS3019 | |
| 22 MM | | LS5022 |
| 25 MM | | LS5025 |
| 28 MM | | LS5028 |

All new collar splitters are supplied with a full set of blades

HYDRADRIV[®] DOUGHNUT

19mm STD + 19mm BOM

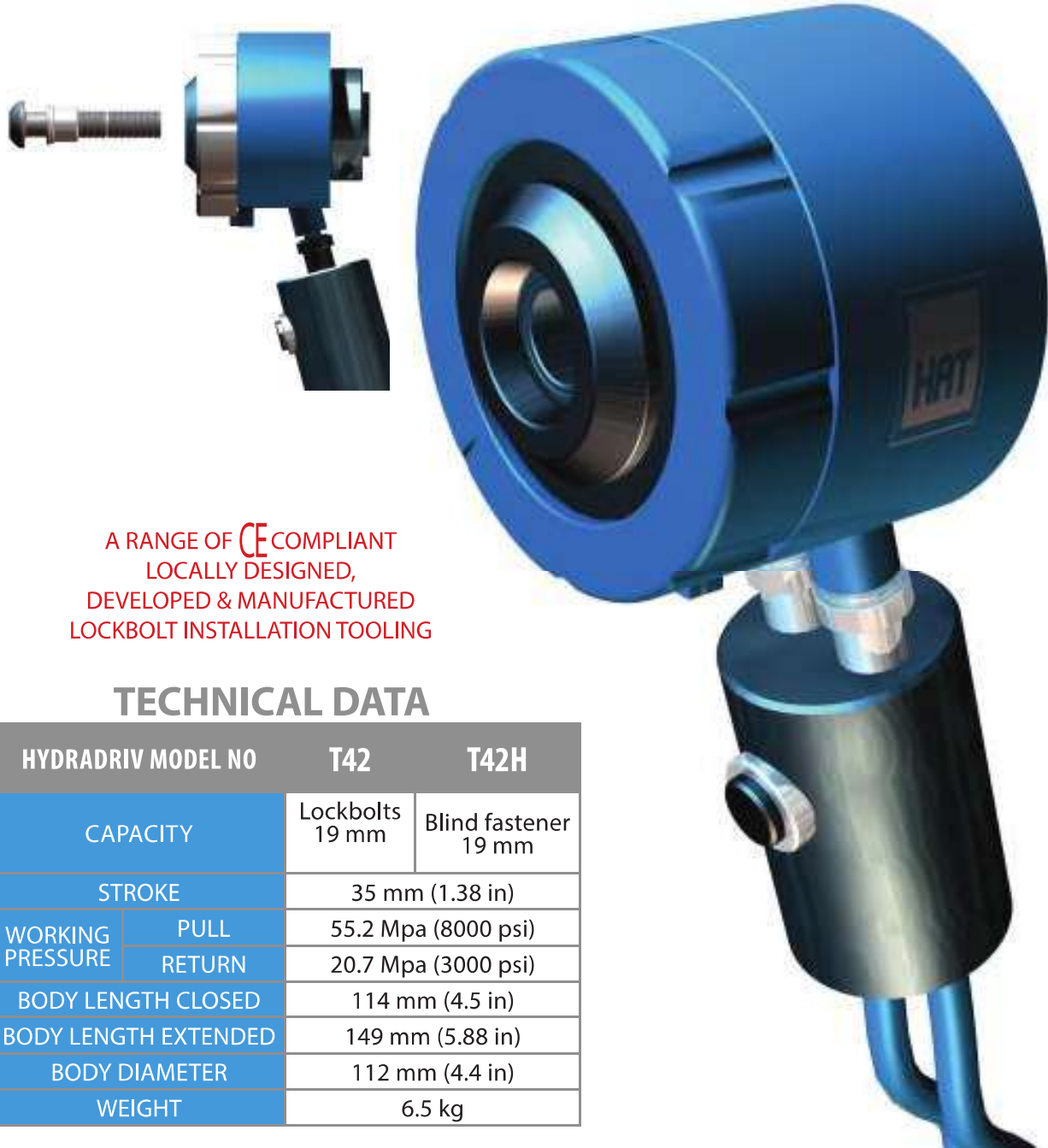

A RANGE OF CE COMPLIANT
 LOCALLY DESIGNED,
 DEVELOPED & MANUFACTURED
 LOCKBOLT INSTALLATION TOOLING

TECHNICAL DATA

| HYDRADRIV MODEL NO | | T42 | T42H |
|----------------------|--------|---------------------|-------------------------|
| CAPACITY | | Lockbolts 19 mm | Blind fastener 19 mm |
| STROKE | | 35 mm (1.38 in) | |
| WORKING PRESSURE | PULL | 55.2 Mpa (8000 psi) | |
| | RETURN | 20.7 Mpa (3000 psi) | |
| BODY LENGTH CLOSED | | 114 mm (4.5 in) | |
| BODY LENGTH EXTENDED | | 149 mm (5.88 in) | |
| BODY DIAMETER | | 112 mm (4.4 in) | |
| WEIGHT | | 6.5 kg | |

Data shown is subject to change without prior notice as a result of continuous product development and improvement . Rev 2014

PNEUMATIC & MANUAL TOOLS

Avlock International offers consistent and reliable installation tooling for breakstem fasteners, structural fasteners, lockbolts, rivnuts & speed fasteners. Constructed from high quality lightweight materials to provide maximum operator comfort.

Innovative, energy saving, low noise level, efficient, lightweight and robust tools are provided for industrial applications.

Pneumatic Riveters



Hand Riveters



SEM

POR GUMPERTZ

Servicios, Equipos y Maquinarias S. P. A.
Una empresa de Ronald Gumpertz

Si le interesa alguno de los productos de este catálogo, contáctenos:

 **Números telefónicos:**

(+56) 9 9682-3138

(+56) 9 4948-2503

 **Dirección de correo electrónico:**

contacto@gumpertz.cl

 **Dirección física:**

Domeyko 2500 (Santiago Centro)

Nuestra empresa

Somos una fábrica e importadora dedicada a la manufacturación y venta de pernos, herramientas industriales, equipos eléctricos, ferretería industrial y maestranza.

Nuestras redes sociales



Sitio web: www.semgumpertz.cl