

# MASTER TUGGER TUBE PULLER



# MASTER TUGGER HYDRAULIC TUBE PULLER

## FEATURES:

- Compact and lightweight gun and powerpack.
- Simple and robust operation.
- High pressure pump for pulling toughest jobs.
- Removes tube without damage.
- Low set up time / ease of operation
- Automatic switchover from low pressure to high pressure.
- Interchangeable pulling gun accessories compatible with existing systems on the market.
- Single man operation.



STPP-300

## TUBE PULLING POWERPACK - SPECIFICATIONS

Model	Volts/ Phase	Power Hp	Oil Tank Capacity Ltrs.	Net Wt. Kgs.	Dimension Mm	Hyd.Hoses Size x Length Inch x mtrs.
STPP-300	230/1	3	10	68	510 x 370 x 680	1/4"x 5 Twin Jack Hose
STPP-300 (Pneumatic)	-	-	10	65	510 x 370 x 680	1/4"x 5 Twin Jack Hose

Note: Max. Working Pressure 700 bar

All power pack supplied with 5 mtr. Long hydraulic hose



## HYDRAULIC TUBE PULLING GUN - SPECIFICATIONS

Gun Model	Pulling Capacity Tons	Max. Tube O.D. Thru Gun Inch	Stub Pulling Capacity Inch	Weight		Free Pulling Speed (Meter/min) with STPP-300
				Kgs.	Lbs.	
SHPG-15	15	1	1.1/2	18	40	3.3
SHPG-30	30	1.1/2	3	25	55	2.0
SHPG-45	45	3	4	51	112	1.3

# MASTER TUGGER HYDRAULIC TUBE PULLER

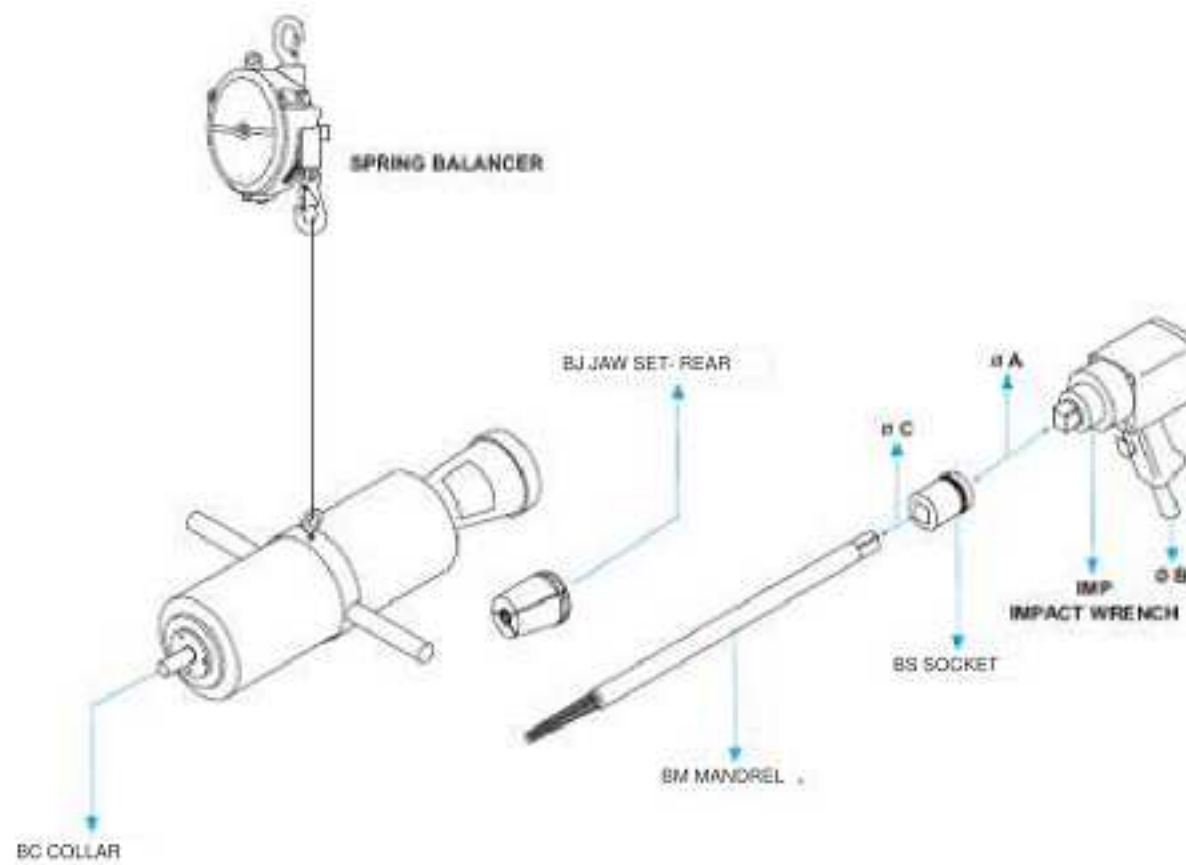

## SPRING BALANCER

\* Used to pulling guns for 'feather touch', operation.

\* Free the operator from handling weight of the gun, allowing him to concentrate on the tube pulling operation.

Model	Balancer Range		For Pulling Gun Model	Weight	
	Kg	Lbs		Kgs.	Lbs.
BSEW-22	15-22	33-48	SHPG-15	8.0	17.6
BSEW-30	22-30	48-66	SHPG-30	9.0	19.8
BSEW-60	50-60	110-132	SHPG-45	12.0	26.4

## IMP - IMPACT WRENCH

\* Used to thread BM mandrels into tube with help of sockets.

Model	Suited For Mandrel Model Numbers	Weight		A	B
		Kg	Lbs		
IMP-1	BM-7 to BM-37	5.0	11.0	3/4"	3/8"
IMP-1	BM-19 to BM-95/102	10.5	23.0	1"	1/2"

## BS = SOCKET

\* Used to connect impact wrench to pulling mandrel.

Model	A	B
BS-1	3/4"	3/8"
BS-2	3/4"	1/2"
BS-3	3/4"	5/8"
BS-4	3/4"	3/4"
BS-5	3/4"	1"
BS-6	1"	3/4"
BS-7	1"	1"
BS-8	1"	1.1/2"

# MASTER TUGGER HYDRAULIC TUBE PULLER

## WORKING CONSUMABLE - CONTINUOUS TUBE PULLER

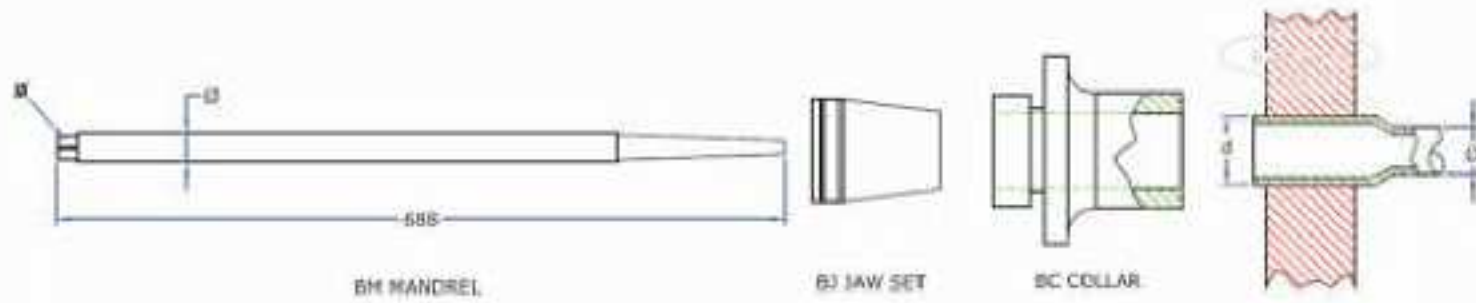

Tube Size		Tube I.D. After Expansion D		Mandrel Model	Mandrel Square Size	Model For SHPG-15 BJ 15	Jaw Set Model For SHPG-30 BJ 30	Model For SHPG-45 BJ 45	Model For SHPG-15 BC 15	Model For SHPG-30 BC 30	Model For SHPG-45 BC 45
OD	Bwg	Inch	Mm	BM	☐						
3/8"	17-19	0.260-0.295	6.5-7.5	7	5/16"	1	1		11	11	
	20-24	0.295-0.335	7.5-8.5	8							
1/2"	14-16	0.335-0.375	8.5-9.5	9	3/8"	2	2		15	15	
	17-18	0.375-0.415	9.5-10.5	10							
	19-21	0.415-0.455	10.5-11.5	11							
	24	0.455-0.495	11.5-12.5	12							
5/8"	16-17	0.495-0.535	12.5-13.5	13A	1/2"	3	3		18	18	
	19-21	0.535-0.570	13.5-14.5	14A							
	23-24	0.570-0.610	14.5-15.5	15A							
3/4"	11	0.495-0.535	12.5-13.5	13	5/8"	4	4		21	21	
	12-13	0.535-0.570	13.5-14.5	14							
	14-15	0.570-0.610	14.5-15.5	15							
	16-17	0.610-0.650	15.5-16.5	16							
	18-20	0.650-0.690	16.5-17.5	17							
	21-24	0.690-0.730	17.5-18.5	18							
7/8"	14	0.690-0.730	17.5-18.5	18 S	5/8"	4/A	4/A		25	25	
	16-17	0.730-0.770	18.5-19.5	19 S							
	18-19	0.770-0.810	19.5-20.5	20 S							
1"	10-11	0.730-0.770	18.5-19.5	19	3/4"	5	5	5	28	28	28
	12	0.770-0.810	19.5-20.5	20							
	13-14	0.810-0.845	20.5-21.5	21							
	15-16	0.845-0.885	21.5-22.5	22							
	18	0.885-0.925	22.5-23.5	23							
	19-20	0.925-0.965	23.5-24.5	24							
3/4" Gas	13	0.845-0.886	21.5-22.5	22 G				6	6		31
	14-15	0.886-0.925	22.5-23.5	23 G							
	16-17	0.925-0.965	23.5-24.5	24 G							
	19-21	0.965-1.005	24.5-25.5	25 G							
1.1/4"	10	0.965-1.005	24.5-25.5	25	1"			7	7		34
	11-12	1.005-1.045	25.5-26.5	26							
	13	1.045-1.085	26.5-27.5	27							
	14-15	1.085-1.125	27.5-28.5	28							
	16-18	1.125-1.160	28.5-29.5	29							
	19-22	1.160-1.200	29.5-30.5	30							
1 Gas	23-24	1.200-1.240	30.5-31.5	31				8	8		37
	9	1.005-1.045	25.5-26.5	26 G							
	10	1.045-1.085	26.5-27.5	27 G							
	11-12	1.085-1.125	27.5-28.5	28 G							
1.1/2"	13-14	1.125-1.160	28.5-29.5	29 G				9	9		41
	10-11	1.240-1.280	31.5-32.5	32							
	12-13	1.280-1.320	32.5-33.5	33							
	14	1.320-1.360	33.5-34.5	34							
	15-17	1.360-1.400	34.5-35.5	35							
	18-20	1.400-1.440	35.5-36.5	36							
	21-24	1.440-1.475	36.5-37.5	37							

**NOTE:** For Tubes larger than 3"O.D., Please contact us for larger size working consumable & larger size tube pulling guns. All models indicated above are for continuous pulling. When you are using equipment for stub pulling. Please contact us for modifications needed.

# MASTER TUGGER HYDRAULIC TUBE PULLER

## WORKING CONSUMABLE - CONTINUOUS TUBE PULLER

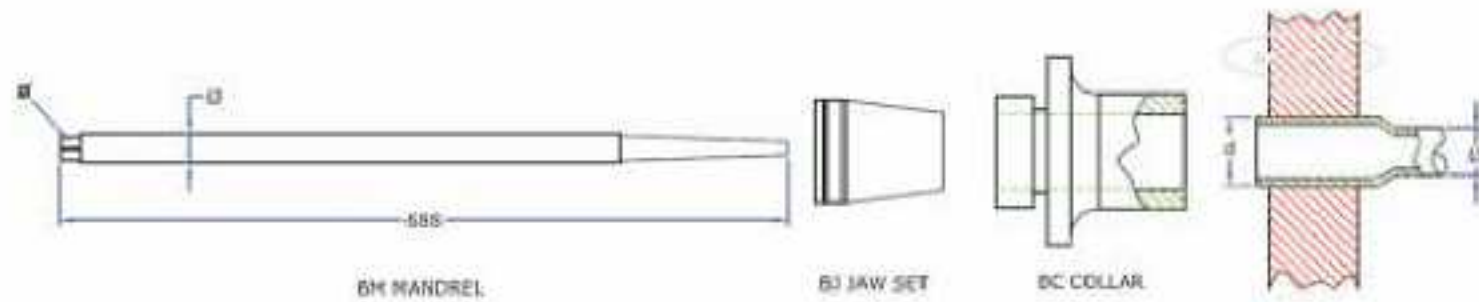

Tube Size		Tube I.D. After Expansion		Mandrel		Jaw Set			Collar																
OD	Bwg	Inch	Mm	Model	Square Size	Model For SHPG-15	Model For SHPG-30	Model For SHPG-45	Model For SHPG-15	Model For SHPG-30	Model For SHPG-45														
				BM	□	BJ 15	BJ 30	BJ 45	BC 15	BC 30	BC 45														
1.1/4" Gas	12	1.440-1.475	36.5-37.5	37 G	1"																				
	13-14	1.475-1.515	37.5-38.5	38 G																					
	15-16	1.515-1.555	38.5-39.5	39 G								10	10	44	44										
	17-19	1.555-1.595	39.5-40.5	40 G																					
	20-24	1.595-1.635	40.5-41.5	41 G																					
1.3/4"	10-11	1.475-1.515	37.5-38.5	38/44																					
	12	1.515-1.555	38.5-39.5	39/44																					
	13-14	1.555-1.595	39.5-40.5	40/44								11						48							
	15-16	1.595-1.635	40.5-41.5	41/44																					
	18-19	1.635-1.675	41.5-42.5	42/44																					
	20-24	1.675-1.715	42.5-43.5	43/44																					
1.1/2" Gas	11-12	1.715-1.755	42.5-43.5	43G															12						53
	13-14	1.755-1.795	43.5-44.5	44G																					
	15-17	1.795-1.830	44.5-54.5	45G																					
	18-19	1.830-1.870	45.5-46.5	46G																					
2"	10	1.830-1.870	43.5-44.5	44/51								13						54							
	11-12	1.870-1.910	44.5-45.5	45/51																					
	13	1.910-1.950	45.5-46.5	46/51																					
	14-15	1.950-1.990	46.5-47.5	47/51																					
	16-18	1.870-1.910	47.5-48.5	48/51																					
	19-22	1.910-1.950	48.5-49.5	49/51																					
2.1/4"	9-10	1.950-1.990	49.5-50.5	50/57								14						60							
	11	1.990-2.030	50.5-51.5	51/57																					
	12-13	2.030-2.070	51.5-52.5	52/57																					
2" Gas	7	1.990-2.030	50.5-51.5	51G	15						63														
	8	2.030-2.070	51.5-52.5	52G																					
	9	2.070-2.105	53.5-53.5	53G																					
2.1/2"	7	2.015-2.145	53.5-54.5	54/63	16						66														
	8	2.145-2.185	54.5-55.5	55/63																					
	9	2.185-2.225	55.5-56.5	56/63																					
	10	2.225-2.265	56.5-57.5	57/63																					
3"	7	2.580-2.620	66.5-67.5	67/76	17						80														
	8	2.620-2.660	67.5-68.5	68/76																					
	9-10	2.660-2.695	68.5-69.5	69/76																					
	11	2.695-2.735	69.5-70.5	70/76																					